

ALL NEW

LUNDBERG 4260



 **Lundberg**

**Building a better world
with fewer machines.**

ENGINE

Deutz TCD 2.9 L4, Stage 5	
Output (DIN)	55,4 kW
Torque	300 Nm

POWERTRAIN

Hydrostatic, variable displacement pump and motor.
Mechanical transport gear with electric control.

Gears forward/backward	1/1
Max tractive force	24,2 kN
Speed	0 – 50 km/h

HYDRAULIC SYSTEM

Load-sensing operating hydraulics with electric pilot control. Pump with variable displacement, double-acting hydraulic

Maximum flow of hydraulic oil	160 l/min
Operating pressure	24 Mpa

FRAME

Articulated steering and oscillating frame.

Max. steering angle	± 43°
Max. oscillation angle	± 11°

WHEELS

As standard	340/80R18
-------------	-----------

BRAKES

Hydraulic power-assisted brakes in oil bath on both front and rear axles. Electro-hydraulic parking brake on the rear axle.

ELECTRIC SYSTEM

Voltage	24 V
Alternator	100 A

DIMENSIONS

Height	2170 mm
Width (between the outer flanks of the tyres)	1620 mm
Turning radius (outside wheels)	3834 mm
Capacity of the fuel tank	80 l
Capacity of the AdBlue tank	-
Weight without work attachments	3500 kg

LOADER

Lifting height	2877 mm
----------------	---------

LIFTING FORCES

	Front face of the quick-coupler
Hydraulic lifting force, lower position	30 kN
Hydraulic lifting force, upper position	38 kN
Break-out force of the bucket	27 kN

Lundberg

4260

INCLUDED AS STANDARD

- Motor hydraulics
 - 2-way front 0-160 l/min
- Motor hydraulic flow in display
- output of the motor hydraulics can be automatically adjusted based on machine speed
- 3rd cylinder hydraulics 0-65 l/min
- Electronic crawl and accelerator pedals
- 24 V socket in front and rear
- LED-beacon
- 7" Display
- Reversing warning with on/off
- Radio/Bluetooth/AUX-in/USB
- Windshield wiper and washer in front and rear
- LED working light front and rear
- Height and depth adjustable steering wheel
- Seat warmer
- 2-point seat belt
- Programmable attachment and driver profiles
- ROPS (ISO 3471)
- FOPS (ISO 3449 1365 J)
- Cruise control

OPTIONS

- Hydraulic rear quick coupler (kunta 500, Vila, Volvo and Trima)
- 2-way motor hydraulics, rear 0-130 l/min
- 4th cylinder hydraulics
- 5th cylinder hydraulics
- 6th cylinder hydraulics
- Central lubrication
- Automatic AC
- Seat with air suspension, 3 point seat belt
- Eberspächer heater
- Engine heater
- Hydraulic oil heater
- Electric cabin heater
- Cabin storage box
- Reverse camera
- Trailer brake valve
- Various tow hitch options
- 2 + 2 LED extra work light
- 8 kpl LED warning beacons
- 4 kpl LED waistline beacons
- Extra reverse lights
- Higher mount point for driving lights or double driving lights
- Front light above axle
- Multifaster
- Cabin height adjustment
- Custom color options
- Programmable joystick
- Faster steering
- Anti-Theft System
- Anti-glare curtain
- Mugholder
- Heated windshield
- Various tool mounts
- Hi-Fi sound system
- Heated mirrors
- Underbody protection plating

Lundberg 4260

www.lannen.com

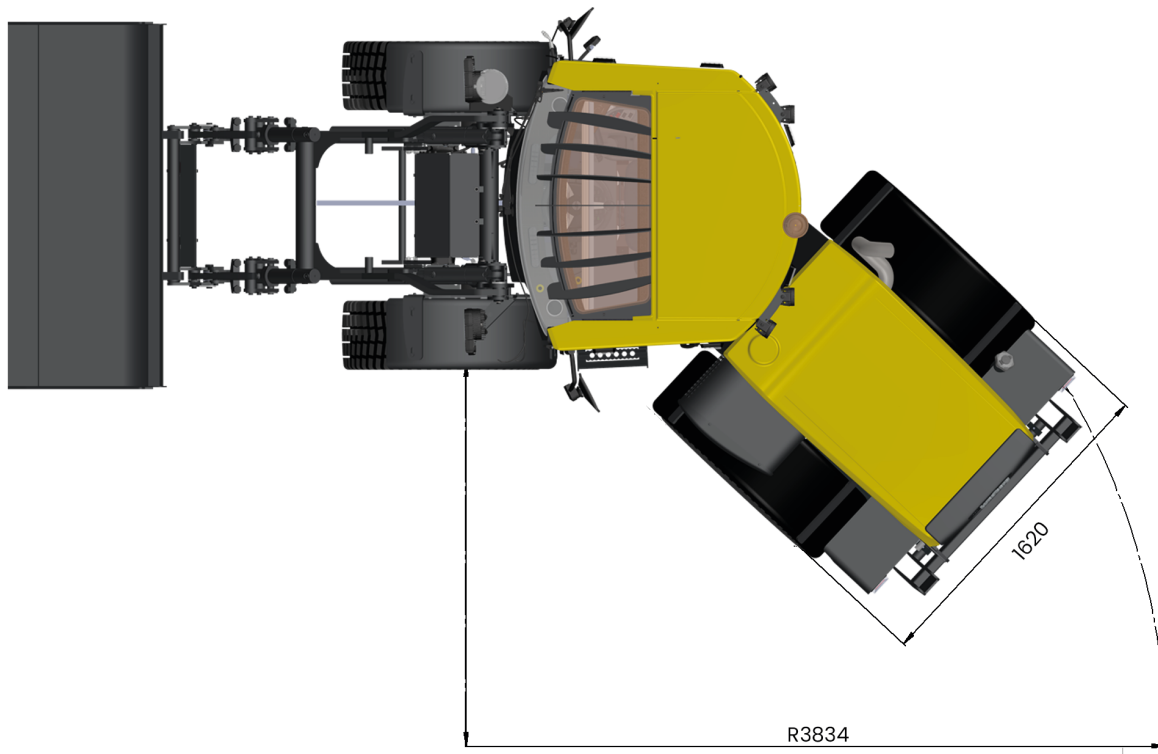
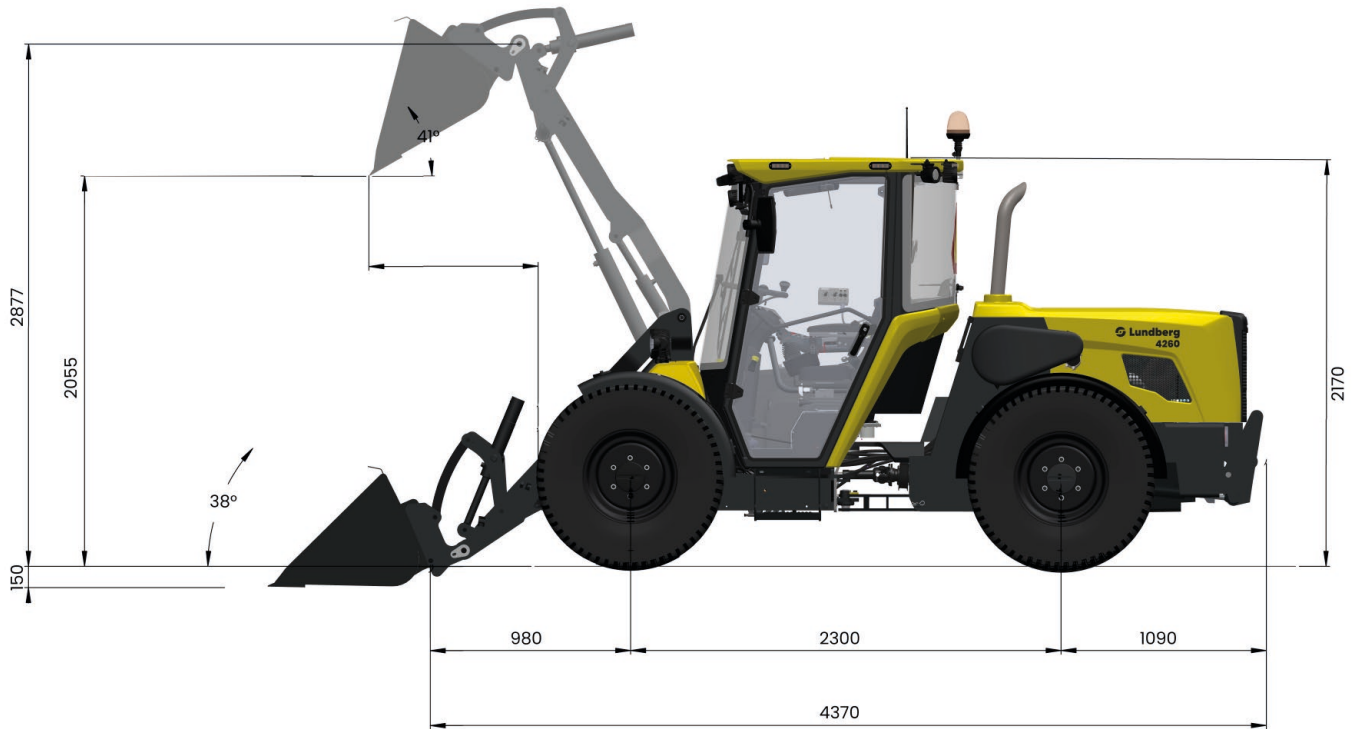

LMCE Group

Building a better world
with fewer machines.

All dimensions and data are at the design stage and are subject to change.